

# HYDRAULIC DIAPHRAGM RANGES

# FC/FE

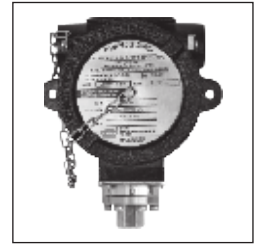

## FE



### PRESSURE CAPSULE DETAILS

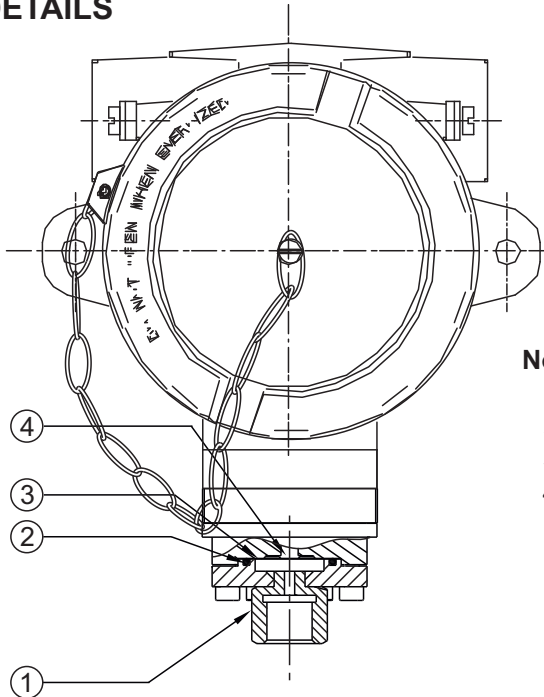

- | No. | Description     |
|-----|-----------------|
| 1.  | Pressure Port   |
| 2.  | PTFE O-Ring     |
| 3.  | Diaphragm       |
| 4.  | Conical Plunger |

Note : *wetted parts* are mentioned in italics. ①

### INSTALLATION DRAWING

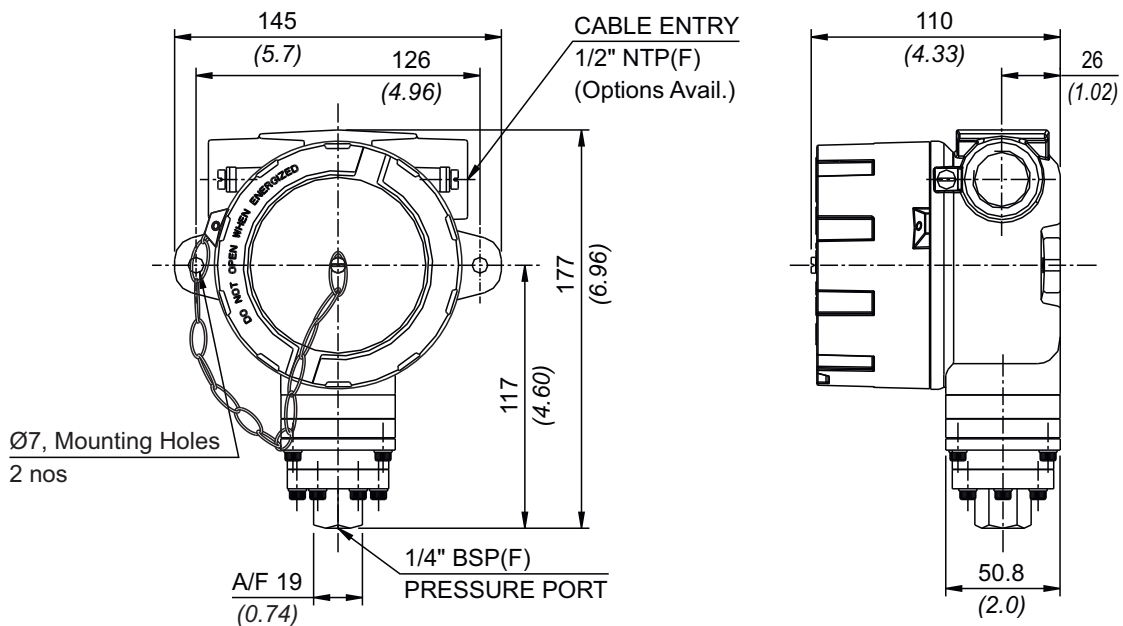

APPROX. DIMENSIONS IN  $\frac{\text{mm}}{\text{inches}}$

# FC/FE HYDRAULIC DIAPHRAGM RANGES

## RANGE SELECTION TABLE

Range Code	Range bar (psi)	Differential* bar (psi)	Maximum Working Pressure bar (psi)
		Approximate Maximum for "A8" microswitch	
H1T	0.5 - 10 (7.25 - 145.04)	1 (14.50)	150 (2175.51)
H2T	2 - 20 (29.00 - 290.07)	2 (29.00)	200 (2900.76)
H4T	5 - 40 (72.52 - 580.15)	5 (72.52)	200 (2900.76)
H1H	10 - 100 (146.04 - 1450.38)	12 (174.05)	200 (2900.76)
H2H	7 - 200 (101.52 - 2900.76)	24 (348.09)	400 (5801.52)
H4H	40 - 400 (580.15 - 5801.52)	50 (725)	500 (7251.88)
H7H	70 - 700 (1015.26 - 10152.64)	60 (870)	800 (11603)
H1K	100 - 1000 (1450.37 - 14503.77)	70 (1015.26)	1100 (15954.15)

**Note:**

1. The minimum differential increases with the setpoint. The differential values mentioned in the above table are approximate maximum for FSR. The differential value will vary according to the pressure range selected and microswitch type. For actual values of differential please contact sales office.

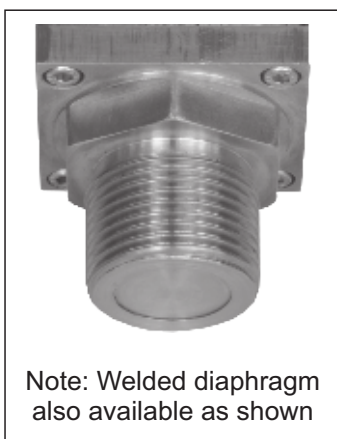

Note: Welded diaphragm also available as shown

2. When using 2SPDT switching arrangement, both microswitches may not actuate and/or deactuate at the same point. A small stage gap, normally upto +/- 5% FSR (depending on range code) may be observed. The On-Off differential (hysteresis) typically tends to be atleast double of those published for 1SPDT pressure switches.

If actuation and/or deactuation at same point is critical part of operation, then it can be achieved by using a separate DPDT relay. This relay will need a separate power supply for it's coil.

# HOW TO ORDER FLAMEPROOF HYDRAULIC RANGE PRESSURE SWITCHES

## HYDRAULIC DIAPHRAGM RANGES

# FC/FE

Group 1	Group 2	Group 3	Group 4	Group 5	Group 6	Group 7	Group 8												
Non standard allocation	Model	Cable Entry Size	Switch Type	Range Code (values in bar)	Microswitch Type	Pressure Port Material / Size	Diaphragm												
<p>□ A prefix "N" is used in the model code in case of any non standard options / accessories that are provided with the switches. Will be given by manufacturer, only after agreement of supply details with customer.</p> <p>The prefix is subject to change as per specific requirement.</p>	<p><b>FC</b> = IP66 Flameproof pressure switch, ATEX, IECEx &amp; PESO approved</p> <p><b>FE</b> = IP66 Flameproof pressure switch, PESO approved</p>	<p><b>1</b> = Al. head 1/2" NPT threads</p> <p><b>2</b> = Al. head 3/4" NPT threads</p> <p><b>3</b> = Al. head M20 x 1.5 threads</p> <p><b>*4</b> = Grey Cl head 1/2" NPT threads</p> <p><b>*5</b> = Grey Cl head 3/4" NPT threads</p> <p><b>*6</b> = Grey Cl head M20 x 1.5 threads</p> <p><b>7</b> = SS head 1/2" NPT threads</p> <p><b>8</b> = SS head 3/4" NPT threads</p> <p><b>9</b> = SS head M20 x 1.5 threads</p> <p>*Not available in FE models</p>	<p><b>P 1</b> = pressure switch, fixed differential without scale</p> <p><b>P 2</b> = pressure switch, fixed differential with scale in bar</p> <p><b>P 3</b> = pressure switch, fixed differential with scale in psi</p>	<p><b>H1T</b> = (0.5 - 10)</p> <p><b>H2T</b> = (2 - 20)</p> <p><b>H4T</b> = (5 - 40)</p> <p><b>H1H</b> = (10 - 100)</p> <p><b>H2H</b> = (7 - 200)</p> <p><b>H4H</b> = (40 - 400)</p> <p><b>H7H</b> = (70 - 700)</p> <p><b>H1K</b> = (100 - 1000)</p>	<p><b>A1</b> = General purpose microswitch rated at 15 A, 250 VAC</p> <p><b>*A6</b> = elements with adjustable deadband</p> <p><b>*A7</b> = 2SPDT switching elements</p> <p><b>A8</b> = General purpose microswitch rated at 5 A, 250 VAC; 5 A, 28 VDC</p> <p><b>*B7</b> = 2SPDT Switching Elements</p> <p><b>C6</b> = 1SPDT Adjustable Differential</p> <p>Please refer to page nos. 120 &amp; 121 for options and specifications of microswitches</p> <p>* Please contact sales office for additional information</p>	<p><b>S1</b> = SS316 / 1/4" BSP(F)</p> <p><b>S2</b> = SS316 / 1/4" NPT(F)</p> <p><b>S3</b> = (welded diaphragm) SS316 / 1" BSP(M)</p> <p><b>S4</b> = SS316 / 1/2" NPT(F)</p> <p><b>S5</b> = SS316 / 1/2" NPT(M)</p> <p><b>H1</b> = Hastelloy C / 1/4" BSP(F)</p> <p><b>H2</b> = Hastelloy C / 1/4" NPT(F)</p> <p><b>N1</b> = Monel / 1/4" BSP(F)</p> <p><b>N2</b> = Monel / 1/4" NPT(F)</p> <p>More options available, please contact sales office</p>	<p><b>0</b> = Neoprene</p> <p><b>1</b> = PTFE</p> <p><b>2</b> = SS 316L</p> <p><b>3</b> = Hastelloy C</p> <p><b>4</b> = Monel</p> <p><b>5</b> = Titanium</p> <p><b>6</b> = Tantalum</p> <p><b>7</b> = Inconel</p>												
Approx. switch weight in Kgs	<table border="1"> <thead> <tr> <th>Enclosure</th> <th>FC</th> <th>FE</th> </tr> </thead> <tbody> <tr> <td>Aluminium</td> <td>2.210</td> <td>1.710</td> </tr> <tr> <td>Grey Cl</td> <td>4.620</td> <td>4.120</td> </tr> <tr> <td>SS</td> <td>4.720</td> <td>4.220</td> </tr> </tbody> </table>	Enclosure	FC	FE	Aluminium	2.210	1.710	Grey Cl	4.620	4.120	SS	4.720	4.220						
Enclosure	FC	FE																	
Aluminium	2.210	1.710																	
Grey Cl	4.620	4.120																	
SS	4.720	4.220																	
□	FC	1	P1	H4T	A1	S1	2												

eg. A flameproof switch for gas group IIC, with 1/2" NPT cable entry in aluminium housing as 1SPDT pressure switch, having 5 bar to 40 bar pressure range, with 15Amp. microswitch, SS316 pressure housing with 1/4" BSP port size & SS316L diaphragm shall be specified by

Please specify full model number to avoid ambiguity. If only the first two groups are specified while ordering, uncalibrated switches with standard wetted parts and enclosures will be supplied.